

# GLR-5012A

## Rope Head Knotting Machine

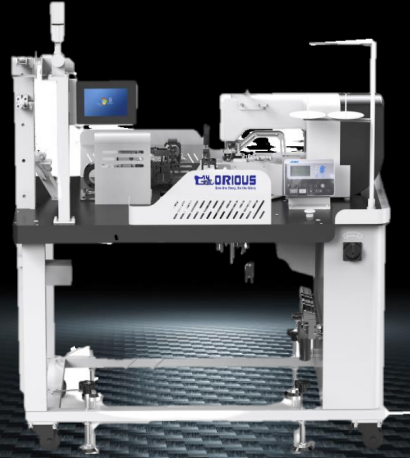





### Range of application

Suitable for knotting the head of all kinds of hoodie rope and trouser rope

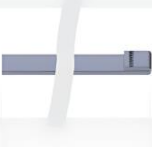

### Specification Range

Single fold Single set of knots	Triple-fold single set of knots	Triple-fold double knot	Heads at both ends	Single-ended head
				
6~20 mm	6~20 mm	6~20 mm	65~300 cm	30~300 cm
10~15 mm	10~15 mm	15.0 mm 16.5 mm 25.0 mm (3 Size)		

### Application Process

Provide matching equipment and components for different processes

#### Hot and cold knife (Standard)



It is suitable for cutting chemical fiber rope and cotton rope without changing the knife

#### Remote Data Collection System (Optional)



Failure Rate Data  
Capacity Data  
Usage Data

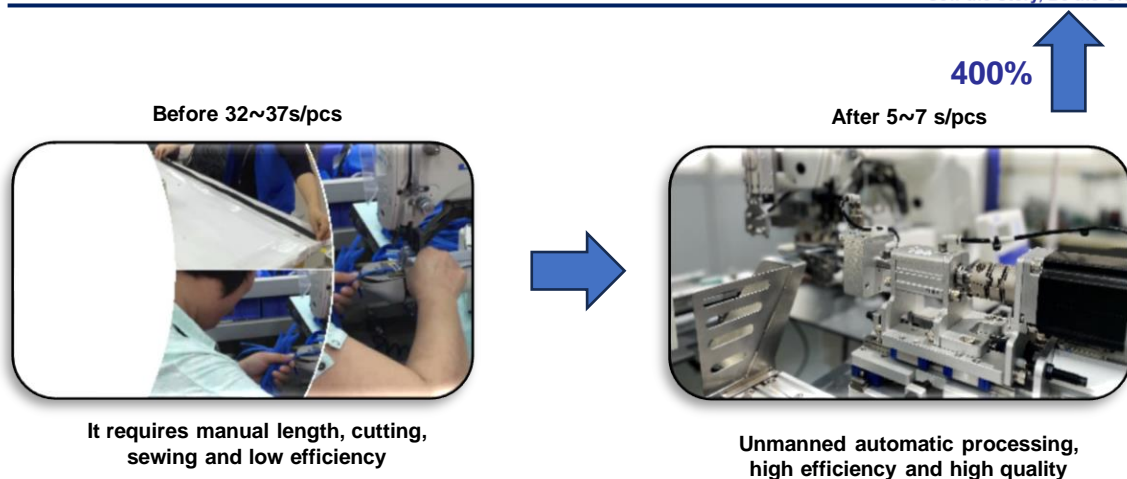

Technical Parameters

Model	GLR-5012A
Voltage	220V 50~60 Hz Single
Power	3.5 KW
Air Pressure	0.5~0.6 MPa
Gas Consumption	7 L/Min
Dimensions	1320 × 750 × 1470 MM
Packing Size	1480 × 880 × 1750 MM
Net Weight	230 KG
Gross Weight	340 KG